

CHAPTER - 4

MICROPROCESSOR & MEMORY CONCEPTS

Topic 1: Microprocessor

Very Short Answer Type Questions (1 mark each)

Question 1:

What do you mean by registers ?

Answer:

It is a small amount of very fast memory that is built into the CPU. It is very expensive. **1**

Question 2:

What do you mean by bus ?

Answer:

It refers to collection of wires through which data is transmitted from one part of computer to another. **1**

Question 3:

What is expansion Bus ?

Answer:

External bus is also known as expansion bus. It connects the different external devices peripherals, expansion slots, input/output ports and drive connections to the rest of the computer. **1**

Question 4:

What is Intel 8085 ?

Answer:

Intel 8085 is a microprocessor that is used in various electronic devices. **1**

Question 5:

What are the three leading microprocessor manufacturing companies ?

Answer:

Intel IBM, Freescale AMD, Microchip MIPS NEC are the three leading companies. **1**

Question 6:

What do you mean by Instruction Set ?

Answer:

The set of instructions that a microprocessor can execute. **1**

Question 7:

What do you understand by Bandwidth ?

Answer:

The number of bits processed in a single instruction. **1**

Question 8:

Define Clock speed.

Answer:

The clock speed determines how many instructions per second a processor can process. It is given in megahertz or gigahertz. **1**

Question 9:

Define chip.

Answer:

It is a small piece of semiconducting material on which an integrated circuit is embedded. **1**

Question 10:

What is the role of clock speed in microprocessor ?

Answer:

It is the speed at which microprocessor executes instructions. **1**

Short Answer Type Questions-II (3 mark each)

Question 1:

Draw the block diagram of microprocessor.

Answer:

Block diagram of microprocessor

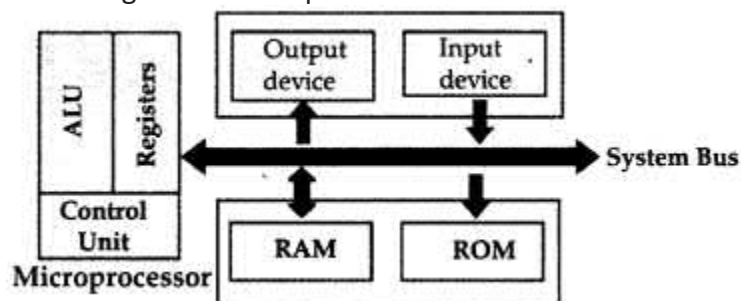

Question 2:

What is microprocessor ? Name its various components.

Answer:

A microprocessor also called CPU is multipurpose, programmable logic device that reads binary instructions from a storage device called memory, accepts binary data as input and processes

data according to those instructions and provides results as output.

Components of Microprocessor:

1. CPU
2. Bus. **3**

Question 3:

What do you understand by registers ? Give the name of two registers.

Answer:

It is a small amount of very fast memory that is built into the CPU. It is very expensive. Accumulator and program counter are two registers. **3**

Question 4:

Write the characteristics on the basis of which microprocessors are differentiated.

Answer:

1. Instruction Set
2. Bandwidth
3. Clock Speed **3**

Question 5:

Expand the following :

1. RISC
2. CISC
3. EPIC

Answer:

1. RISC : Reduced Instruction Set Computing.
2. CISC : Complex Instruction Set Computing.
3. EPIC : Explicitly Parallel Instruction Computing.

[1 mark for each correct answer]

Question 6:

Explain the following :

1. CISC
2. RISC
3. EPIC

Answer:

1. **CISC** : It is acronym for Complex Instruction Set computing. The CISC architecture contains a large set of computer instructions that range from very simple to very complex and specialized.
2. **RISC** : It is acronym for Reduced Instructions Set Computing. It has relatively limited number of instructions. It is designed to perform relatively small number of operations so that it can operate at higher speed.
3. **EPIC** : It is acronym for Explicitly Parallel Instruction Computing. It refers to architecture in which features are provided to facilitate compiler enhancements of Instruction Level Parallelism in all programs while keeping hardware complexity relatively low. **[1 mark for each]**

Question 7:

Write RISC Approach.

Answer:

RISC processors only use simple instructions that can be executed within one clock cycle. Thus, the "MULT" command could be divided into three separate commands: "LOAD," which moves data from the memory bank to a register, "PROD," which finds the product of two operands located within the registers, and "STORE," which moves data from a register to the memory banks. In order to perform the exact series of steps described in the CISC approach, a programmer would need to code four lines of assembly :

```
LOAD A, 2 : 3      LOAD B, 5 : 2
PROD A, B          STORE 2:3, A      3
```

Question 8:

Write CISC Approach.

Answer:

The primary goal of CISC architecture is to complete a task in as few lines of assembly as possible. This is achieved by building processor hardware that is capable of understanding and executing a series of operations. For this particular task, a CISC processor would come prepared with a specific instruction (we'll call it "MULT"). When executed, this instruction loads the two values into separate registers, multiplies the operands in the execution unit, and then stores the product in the appropriate register. Thus, the entire task of multiplying two numbers can be completed with one instruction : MULT 2:3, 5:2. **3**

Question 9:

Write examples of CISC processors.

Answer:

Examples of CISC processors are :

- System/360(excluding the 'scientific' Model 44).
- VAX.
- PDP-11.
- Motorola 68000 family
- Intel x86 architecture based processors. **3**

Question 10:

Write any four points about RISC.

Answer:

Reduced Instruction Set Computer have :

- Small number of instructions.
- Instruction size constant.
- Bans the indirect addressing mode.
- Retains only those instructions that can be overlapped and made to execute in one machine cycle or less. **3**

Topic 2: Memory Concepts

Very Short Answer Type Questions (1 mark each)

Question 1:

Write the full form of CD-ROM.

Answer:

Compact Disk Read Only Memory. **1**

Question 2:

Write the capacity of 3.5 inch floppy disk.

Answer:

1.44 MB. **1**

Question 3:

How many bit for data recording format in most of the modern magnetic tape is needed ?

Answer:

8-bit EBCDIC. **1**

Question 4:

Write the unit of tape speed .

Answer:

Inch per second. **1**

Question 5:

By which reading data is performed in magnetic disk ?

Answer:

Read/write leads. **1**

Question 6:

What do you mean by access time?

Answer:

Seek time + latency time. **1**

Question 7:

What do you mean by seek time ?

Answer:

Time to position the head over proper track. **1**

Question 8:

What do you mean by latency time ?

Answer:

Time to spin the needed data under head. **1**

Question 9:

Hard disk is coated from both the sides by

Answer:

Magnetic metallic oxide. **1**

Question 10:

How many bytes makes 1KB ?

Answer:

1KB = 1024 bytes. **1**

Question 11:

Write any two advantages of a pen drive.

Answer:

The advantages of a pen drive are :

- Small Size for easy transport
- Affordability. **1**

Short Answer Type Questions-I (2 mark each)

Question 1:

What do you mean by CD-ROM ?

Answer:

CD-ROM is a non-volatile optical data storage medium using the same physical format as audio compact disk, readable by a computer with a CD- ROM drive. The standard 12cm diameter CD-ROM store about 660 megabytes. **2**

Question 2:

What is Blu-ray ?

Answer:

Blu-ray, also known as Blu-ray Disc (BD), is the name of a new optical disk format that offers more than five times the storage capacity of traditional DVDs. **2**

Question 3:

Explain RAM.

Answer:

Computer RAM is the best known form of memory your computer uses. Every file or application opened is placed in RAM. Any information the computer needs or uses becomes part of a continuous cycle where the CPU requests the data from RAM, processes it and then writes new data back to the RAM. This can happen millions of times a second. However, this is just for temporary file storage, so it is deleted when the files or applications are closed. **2**

Question 4:

What do you mean by hard drive ?

Answer:

A hard drive is a form of computer memory that allows you to permanently store data. This is where all of your permanent files and programs are stored. On computers running with Microsoft windows the hard drive is often called C-drive. The size of a hard drive is typically measured in gigabytes. **2**

Question 5:

Explain virtual memory.

Answer:

Virtual memory typically comes into place when applications are too large for the RAM to handle. The operating system uses the hard drive to temporarily store information and take it back when needed. This is normally a lot slower than actual RAM and can possibly degrade the performance if used too heavily. **2**

Question 6:

Where do we use cache memory ?

Answer:

Cache memory is used in between the CPU and the RAM and holds the most frequently used data or instructions to be processed. There are three different grades of cache. **2**

Question 7:

What do you mean by port ? Write its types also.

Answer:

A port is a connection point or interface between a computer and internal or external devices. Some common types of ports are :

1. Serial Port.
2. Parallel Port.
3. USB Port.
4. Bluehx th.
5. PS/2 Port.
6. Infrared Port.
7. Firewire Port. **2**

Question 8:

Explain difference between serial and parallel data transfer.

Answer:

Parallel data transfer refers to the type of data transfer in which a group of bits are transferred simultaneously while serial data transfer refers to the type of data transfer in which a group of data bits are transferred one bit at a time. So that means that the amount of data transferred serially is less than the data transferred parallel per second. **2**

Question 9:

What do you mean by PS/2 port ?

Answer:

A type of port developed by IBM for connecting a mouse or keyboard to a PC. The PS/2 port supports a mini DIN plug containing just 6 pins. Most PCs have a PS/2 port so that the serial port can be used by another device, such as a modem. The PS/2 port is often called the mouse port. **2**

Short Answer Type Questions – II (3 mark each)

Question 1:

Explain 3.5 inch floppy disk.

Answer:

Micro floppy disks (3.5 inch) if it is high density (MF2HD), can store 1.44 MB and if it is low density (MF2DD), can store 720 KB. Mini Floppy disks (5.25 inch) if it is high density (MD2HD), can store 1.2 MB and low density (MD2DD), stores 360 KB of data. **3**

Question 2:

MICR stands for ?

Answer:

MICR (Magnetic Ink Character Reader) is a kind of scanner that can scan and identify the writing of magnetic ink. This device is used in banks to verify the signatures in cheques. **3**

Question 3:

What do you mean by Extended Binary Coded Decimal Interchange Code ?

Answer:

EBCDIC is an 8-bit binary code for larger IBMs primarily mainframes in which each byte represent one alphanumeric character or two decimal digits. 256 characters can be coded using EBCDIC. **3**

Question 4:

Explain Computer memory.

Answer:

Computer memory are internal storage areas in the computer used to either temporarily or permanently store data or instructions to be processed. There are four basic types of computer memory : Cache Memory, RAM, Virtual Memory and Hard Drives. With modern CPU's running at speeds of 1 gigahertz or higher, it is hard for computer memory to keep up with the extreme amount of data being processed. Computer engineers fixed the problem by "tiring" memory. By using this tiring effect, engineers use a small amount of more expensive memory and a large amount of low cost memory. **3**

Question 5:

Pen drives are universal. Explain.

Answer:

The design of a pen drive makes it easy to fit almost anywhere. They can store a large amount of information, sometimes as large as 32 gigabytes. Almost all computers that are designed today have a USB port that allows for extra drives to be attached to access other information on other computer hardware accessories. **3**

Question 6:

Expalin Cache Memory.

Answer:

A CPU cache is a cache used by the Central Processing Unit (CPU) of a computer to reduce the average time to access data from the main memory. The cache is a smaller, faster memory which stores copies of the data from frequently used main memory locations. Most CPUs have different independent caches, including instruction and data caches, where the data cache is usually organized as a hierarchy of more cache levels (L1, L2, etc.)

When the processor needs to read from or write to a location in main memory, it first checks whether a copy of that data is in the cache. If so, the processor immediately reads from or writes to the cache, which is much faster than reading from or writing to main memory.

Most modern desktop and server CPUs have at least three independent caches: an instruction cache to speed up executable instruction fetch, a data cache to speed up data fetch and store, and a translation look aside buffer (TLB) used to speed up virtual-to- physical address translation for both executable instructions and data. The data cache is usually organized as a hierarchy of more cache levels.