

CHAPTER - 13

BOOLEAN ALGEBRA

Question 1:

Which gates are known as universal gates ? Why?

Answer:

Universal gates are the ones which can be used for implementing any gate like AND, OR and NOT or any combination of these basic gates. NAND and NOR gates are universal gates.

Question 2:

Draw the equivalent logic circuit for the following Boolean expression :

Answer:

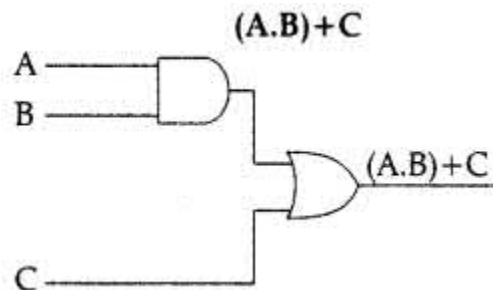

Question 3:

Express the OR operator in terms of AND and NOT operator.

Answer:

$$\overline{(A \cdot B)} = \overline{A} + \overline{B}$$
$$\overline{(\overline{A} + \overline{B})} = A \cdot B$$

Question 4:

Specify which axioms/theorems are being used in the following Boolean reductions :

- (a) $(be)' + be = 1$
- (b) $xyz + zx = xz$

Answer:

- (a) $x + x' = 1$ & Complementary law
- (b) $y + x = x$ & Absorption law.

Question 5:

State and verify Associative law using Truth Table.

Answer:

Associative Law: This law states that:

$$(A + B) + C = A + (B + C)$$

$$(A.B).C = A.(B.C)$$

Proof:

A	B	C	A + B	(A + B) + C	B + C	A + (B + C)
0	0	0	0	0	0	0
0	0	1	0	1	1	1
0	1	0	1	1	1	1
0	1	1	1	1	1	1
1	0	0	1	1	0	1
1	0	1	1	1	1	1
1	1	0	1	1	1	1
1	1	1	1	1	1	1

∴ From above truth table,

$$(A + B) + C = A + (B + C)$$

Similarly, we can prove,

$$A.(B.C) = (A.B).C$$

A	B	C	B.C	A.(B.C)	A.B	(A.B).C
0	0	0	0	0	0	0
0	0	1	0	0	0	0
0	1	0	0	0	0	0
0	1	1	1	0	0	0
1	0	0	0	0	0	0
1	0	1	0	0	0	0
1	1	0	0	0	1	0
1	1	1	1	1	1	1

Short Answer Type Questions-I [2 mark each]

Question 1:

Correct the following boolean statements :

1. $X+1 = X$
2. $(A')' = A'$
3. $A+A' = 0$
4. $(A+B)' = A.B$

Answer:

1. $X+1=1$ or $X+0=X$
2. $((A')') = A$

3. $A + A' = 1$ or $A \cdot A' = 0$
 4. $(A - B)' = A' \cdot B$

Question 2:

Write the POS form of a Boolean Function F, which is represented in a truth table as follows :

P	Q	R	F
0	0	0	0
0	0	1	1
0	1	0	1
0	1	1	1
1	0	0	1
1	0	1	0
1	1	0	0
1	1	1	1

Answer:

$$(P+Q+R).(P'+Q+R).(P'+Q'+R)$$

Short Answer Type Questions-II [3 mark each]

Laws and Theorems

Question 1:

State and Verify Absorption law algebraically.

Answer:

Absorption law states that :

$$A + AB = A \text{ and } A \cdot (A + B) = A$$

Algebraic method :

Taking LHS

$$A + AB = (A \cdot I) + (A \cdot B) \text{ by Identity}$$

$$= A \cdot (1 + B) \text{ by Distribution}$$

$$= A \cdot I \text{ by Null Element}$$

$$= A$$

Question 2:

State and define principle of duality. Why is it so important in Boolean Algebra ?

Answer:

Principle of duality : Duality principle states that from every boolean relation another boolean relation can be derived by :

(i) Changing each OR sign (+) to an AND sign (-).

(ii) Changing each AND sign (-) to an OR sign (+)

ex : Dual of $A + A'B = A \cdot (A' + B)$

Importance in Boolean Algebra : The principle of duality is an important concept in Boolean algebra, particularly in proving various theorems. The principle of duality is used extensively in proving Boolean algebra theorem. Once we prove that an expression is valid, by the principle of duality, its dual is also valid. Hence, our effort in proving various theorems is reduced to half.

Question 3:

Name the law shown below & verify it using a . truth table.

$$X + \bar{X} \cdot Y = X + Y.$$

Answer:

This law is called “Absorption Law” also referred as redundance law.

Prove by Truth table

X	Y	X'	$X + X' \cdot Y$	$X + Y$
0	0	1	0	0
0	1	1	1	1
1	0	0	1	1
1	1	0	1	1

Question 4:

Draw a logic circuit for the following Boolean expression : $ab + c \cdot d'$.

Answer:

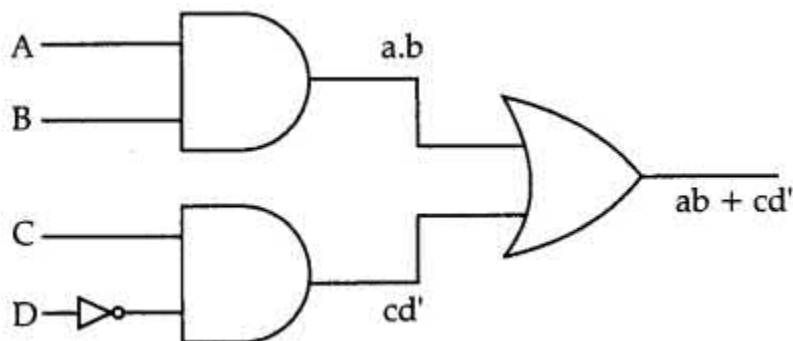

Question 5:

Write the SOP form of a Boolean function F, which is represented in a truth table as follows :

A	B	C	F
0	0	0	0
0	0	1	1
0	1	0	1
0	1	1	0
1	0	0	1
1	0	1	1
1	1	0	0
1	1	1	0

Answer:

$$A'B'C + A'BC + AB'C + AB'C$$

Question 6:

Draw the Logic Circuit for the following Boolean Expression :

$$(U + V) \cdot w + z$$

Answer:

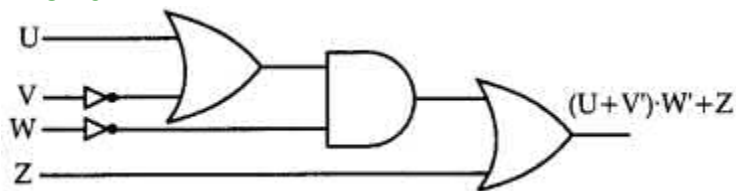

Question 7:

Verify the following using Boolean Laws :

$$LT + V = LTV + LP.V + U.V$$

Answer:

$$\begin{aligned}
 & \text{L.H.S.} \\
 & = U' + V \\
 & = U' \cdot (V + V) + V (LP + U) \\
 & = U' \cdot V + LP \cdot V + U \cdot V + U \cdot V \\
 & = U' \cdot V + LP \cdot V + U \cdot V \\
 & = \text{R.H.S.}
 \end{aligned}$$

OR

$$\begin{aligned}
 &\text{R.H.S.} \\
 &= U'V' + U'.V + U.V \\
 &= LP . (V + V) + U.V \\
 &= U' 1 + U.V \\
 &= U' + U.V \\
 &= U' + V \\
 &= \text{L.H.S.}
 \end{aligned}$$

Question 8:

Draw the Logic Circuit for the following Boolean Expression :
 $(X' + Y). Z + W'$

Answer:

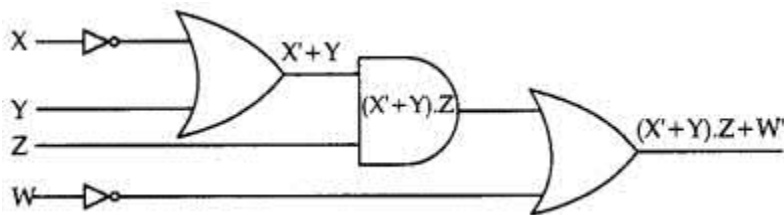

Question 9:

Write the equivalent boolean expression for the following logic circuit.

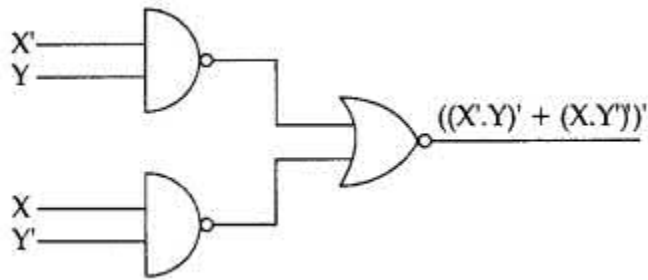

Answer:

$$((X'.Y)' + (X.Y'))'$$

Question 10:

Write the equivalent Boolean Expression for the. following Logic Circuit :

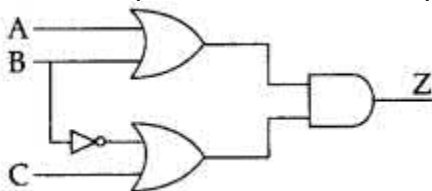

Answer:

$$\begin{aligned} Z &= (A+B)(B' +C) \\ &= A.B' + AC + B.B' + BC \\ &= A.B' + AC + BC \end{aligned}$$

Question 11:

Obtain the Boolean Expression for the logic circuit shown below :

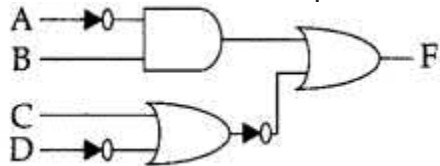

Answer:

$$\begin{aligned} F &= (\overline{A}.B) + (C + \overline{D}) \\ &= (\overline{A}.B) + \overline{C}.D \end{aligned}$$

Question 12:

Name the law shown below & verify it using a truth table.

$$A + B . C = (A + B) . (A + C).$$

Answer:

This law is called "Distributive Law".

Prove by Truth table

A	B	C	A+B.C	A+B	A+C	(A+B).(A+C)
0	0	0	0	0	0	0
0	0	1	0	0	1	0
0	1	0	0	1	0	0
0	1	1	1	1	1	1
1	0	0	1	1	1	1
1	0	1	1	1	1	1
1	1	0	1	1	1	1
1	1	1	1	1	1	1

Question 13:

Obtain the Boolean Expression for the logic circuit shown below :

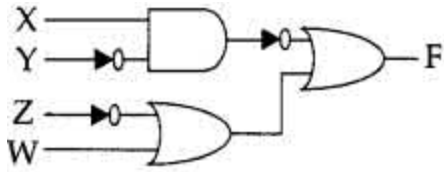

Answer:

$$F = (X.Y) + (Z + W).$$

$$F = \overline{X} + Y + \overline{Z} + W.$$

Question 14:

State Demorgan's law. Verify one of them using truth table.

Answer:

There are two Demorgan's law :

- (i) $\overline{A.B} = \overline{A} + \overline{B}$
- (ii) $\overline{A + B} = \overline{A} . \overline{B}$

Proof :

- (i) $\overline{A.B} = \overline{A} + \overline{B}$

A	B	\overline{A}	\overline{B}	$\overline{A.B}$	$\overline{A} + \overline{B}$
0	0	1	1	1	1
0	1	1	0	1	1
1	0	0	1	1	1
1	1	0	0	0	0

Question 15:

Draw a logic Circuit for the boolean expression:

$$A . \overline{B} + (C + \overline{B}) . \overline{A}$$

Answer:

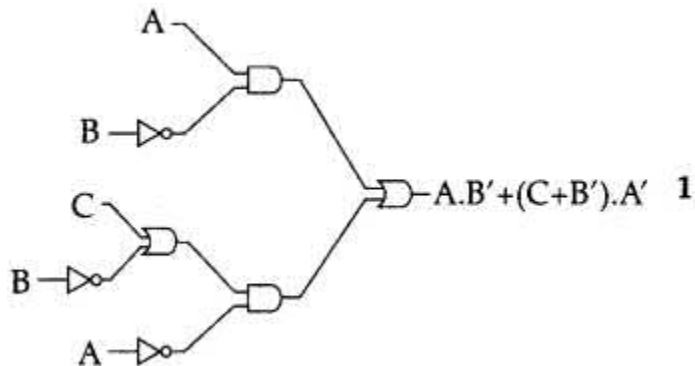

Question 16:

Obtain the Boolean Expression for the logic circuit shown below :

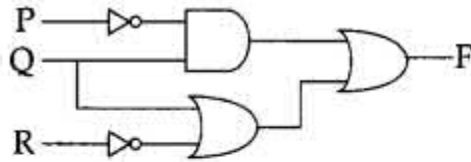

Ans.

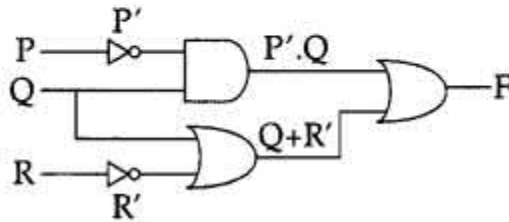

$$F = P' Q + (Q + R')$$

$$= Q \cdot (P' + R')$$

Question 17:

Verify the following using Boolean Laws $X + Z = X + X' \cdot Z + Y \cdot Z$

Answer:

Taking RHS

$$X + X'Z + YZ$$

$$= (X + X') \cdot (X + Z) + YZ \text{ (Distribution Law)}$$

$$= 1 \cdot (X + Z) + YZ \quad (A + A' = 1)$$

$$= X + Z + YZ$$

$$= X + Z (1 + Y)$$

$$= X + Z \quad (1 + A = 1; 1 \cdot A = A)$$

$$= \text{Hence verified}$$

Question 18:

Verify the following using Boolean Laws : $A + C = A + A' \cdot C + B \cdot C$

Answer:

$$A + C = A + A' \cdot C + BC$$

Solve RHS

$$A + A' \cdot C + BC$$

$$(A + A') \cdot (A + C) + BC \text{ [Using distributive law]}$$

$$1 \cdot (A + C) + BC$$

$$= A + C + BC$$

$$= A + C(1 + B)$$

$$= A + C \cdot 1$$

$$= A + C$$

$$= \text{LHS (Hence, verified)}$$

Question 19:

Obtain the Boolean Expression for the logic circuit shown below :

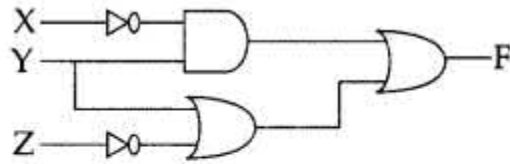

Ans.

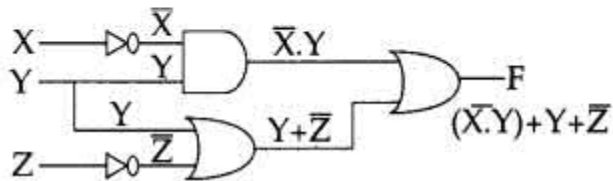

Expression at F :

$$(\bar{X} \cdot Y) + (Y + \bar{Z})$$

$$(\bar{X} + 1) Y + \bar{Z} \quad [\text{Distributive law}]$$

$$Y + \bar{Z} \quad [\because 1 + Z = 1]$$

Question 20:

Verify the following using truth table :

(i) $X \cdot X' = 0$

(ii) $X + 1 = 1$

Answer:

(i)

X	X'	Y=X.X'
0	1	0
1	0	0

(ii)

X	1	Y=X+1
0	1	1
1	1	1

Question 21:

Write the equivalent boolean expression for the following logic circuit :

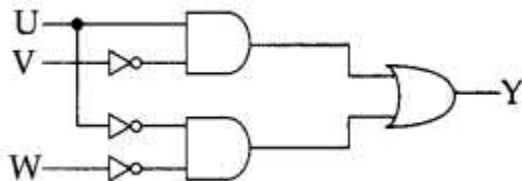

Answer:

$$Y = U \bar{V} + \bar{U} \bar{W}$$

Question 22:

Write the equivalent boolean expression for the following logic circuit :

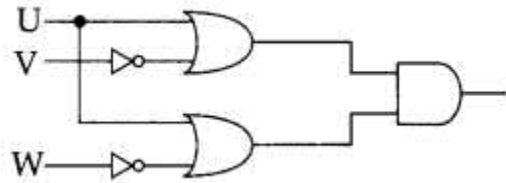

Answer:

$$Y = (U + \bar{V}) \cdot (U + \bar{W})$$

Question 23:

Verify the following using truth table :

(i) $X + 0 = X$

(ii) $X + X' = 1$

Answer:

(i)

X	0	Y = X + 0
0	0	0
1	0	1

Hence, $X + 0 = X$

(ii)

X	X'	Y = X + X'
0	1	1
1	0	1

Hence, $X + X' = 1$

Question 24:

Derive a Canonical SOP expression for a Boolean function F, represented by the following truth table :

A	B	C	F(A,B,C)
0	0	0	1
0	0	1	0
0	1	0	0
0	1	1	1
1	0	0	1
1	0	1	0
1	1	0	0
1	1	1	1

Answer:

$$F(A, B, C) = A'B'C + A'BC + AB'C + ABC$$

OR

$$F(A,B,C) = \sum(0, 3,4,7)$$

Question 25:

Derive a Canonical POS expression for a Boolean function F, represented by the following truth table :

P	Q	R	F(P, Q, R)
0	0	0	1
0	0	1	0
0	1	0	0
0	1	1	1
1	0	0	1
1	0	1	0
1	1	0	0
1	1	1	1

Answer:

$$F(P,Q,R) = (P+Q+R')(P+Q,+R)(P'+Q,+R') (P'+Q'+R)$$

OR

$$F(P,Q,R) = \prod(1,2,5,6)$$

Question 26:

Obtain a simplified form for a Boolean expression :
 $F(U, V, W, Z) = \Pi (0,1,3,5, 6, 7,15)$

Answer:

	$w+z$	$w+z'$	$w'+z'$	$w'+z$
$u+v$	0 0	0 1	0 3	2
$u+v'$	4	0 5	0 7	0 6
$u'+v'$	12	13	0 15	0 4
$u'+v$	8	9	11	0 0

$(u + v + w).(u+z').(v'+w').(u'+w'+z)$

Question 27:

Reduce the following Boolean Expression to its simplest form using K-Map :
 $F(X, X Z, W) = X (0,1, 6, 8, 9,10,11,12,15)$

Answer:

	$X'Y'$	$X'Y$	XY	XY'
$Z'W'$	1		1	1
$Z'W$	1			1
ZW				1
ZW'		1		1

OR

	Z'W'	Z'W	ZW	ZW'
X'Y'	1	1		
X'Y				1
XY	1		1	
XY'	1	1	1	1

Simplified Expression : $XY + Y'Z' + XZ'W' + XZW + X'YZW'$

Question 28:

Reduce the following Boolean Expression to its simplest form using K-Map :

$$F(X, Y, Z, W) = X(0,1,4, 5,6, 7,8, 9,11,15)$$

Answer:

	X'Y'	X'Y	XY	XY'
Z'W'	1	1		1
Z'W	1	1		1
ZW		1	1	1
ZW'		1		

OR

	Z'W'	Z'W	ZW	ZW'
X'Y'	1	1		
X'Y	1	1	1	1
XY			1	
XY'	1	1	1	

Simplified Expression : $Y'Z' + XY + XZW$

Question 29:

Verify the following using Boolean Laws.

$$X + Y' = X \cdot Y + X \cdot Y' + X' \cdot Y$$

Answer:

L. H. S.

$$= X + Y'$$

$$= X \cdot (Y + Y') + (X + X') \cdot Y'$$

$$= X \cdot Y + X \cdot Y' + X \cdot Y' + X' \cdot Y'$$

$$= X \cdot Y + X \cdot Y' + X' \cdot Y'$$

= R. H. S

OR

$$= X \cdot Y + X \cdot Y' + X' \cdot Y'$$

$$= X \cdot (Y + Y') + X' \cdot Y'$$

$$= X \cdot 1 + X' \cdot Y'$$

$$= X + X' \cdot Y'$$

$$= X + Y$$

= L. H. S

Question 30:

State Distributive law and verify it using truth table.

Answer:

Distributive law : This law states that

(i) $x(y + z) = xy + x.z.$

(ii) $x + yz = (x + y)(x + z)$

Now let us prove using truth table.

(i)

x	y	z	y + z	x(y + z)	xy	x.z	x.y + x.z
0	0	0	0	0	0	0	0
0	0	1	1	0	0	0	0
0	1	0	1	0	0	0	0
0	1	1	1	0	0	0	0
1	0	0	0	0	0	0	0
1	0	1	1	1	0	1	1
1	1	0	1	1	1	0	1
1	1	1	1	1	1	1	1

Hence $x(y + z) = x.y + x.z$

(ii)

x	y	z	yz	x+yz	x+y	x+z	(x+y)(x+z)
0	0	0	0	0	0	0	0
0	0	1	0	0	0	1	0
0	1	0	0	1	1	0	0
0	1	1	1	1	1	1	1
1	0	0	0	1	1	1	1
1	0	1	0	1	1	1	1
1	1	0	0	1	1	1	1
1	1	1	1	1	1	1	1

Hence $x + yz = (x + y).(x + z)$

[2]

Question 31:

Reduce the following Boolean Expression using KMap :

$F(A, B, C, D) = \sum\{0, 1, 3, 5, 6, 7, 9, 11, 13, 14, 15\}$

Answer:

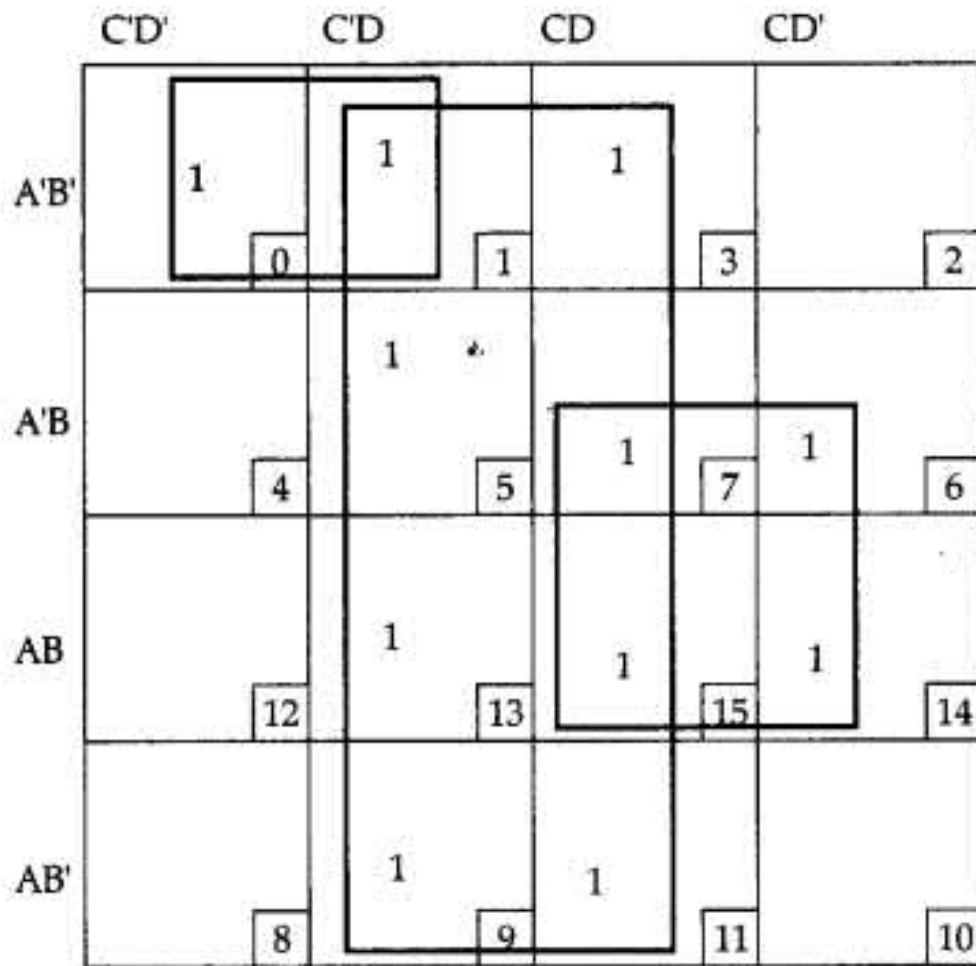

$$A'B'C + D + BC$$

TOPIC-2

Karnaugh Map Minimization and Applications of Boolean Algebra

Very Short Answer Type Questions [1 mark each]

Question 1:

Write Product of Sum expression of the function F (a, b, c, d) from the given truth table

a	b	c	d	f
0	0	0	0	0
0	0	0	1	0
0	0	1	0	1
0	0	1	1	1
0	1	0	0	0
0	1	0	1	1
0	1	1	0	1
0	1	1	1	0
1	0	0	0	0
1	0	0	1	0
1	0	1	0	1
1	0	1	1	1
1	1	0	0	0
1	1	0	1	0
1	1	1	0	0
1	1	1	1	1

Answer:

F (a, b, c, d) =

$$(a + b + c + d) \cdot (a + b + c + d') \cdot (a + b' + c + d) \cdot (a + b' + c' + d') \cdot (a' + b + c + d) \cdot (a' + b + c + d')$$

$$\cdot (a' + b' + c + d) \cdot (a' + b' + c + d') \cdot (a' + b' + c' + d)$$

Question 2:

Convert the following boolean expression into its equivalent Canonical Sum of Products form (SOP) :

$$(U + V + W) (U + V + W') (U' + V + W) (U' + V' + W')$$

Answer:

$$\pi (0,1, 4, 7)$$

$$\Sigma(2, 3, 5, 6)$$

$$010\ 011\ 101\ 110$$

$$= U'VW' + U'VW + UV'W + UVW'$$

Question 3:

Write the Sum of Product form of the function F(P, Q, R) for the following truth table representation of F :

P	Q	R	F
0	0	0	1
0	0	1	0
0	1	0	0
0	1	1	1
1	0	0	0
1	0	1	0
1	1	0	1
1	1	1	1

[Delhi, 2014]

Ans. $\overline{P}\overline{Q}\overline{R} + \overline{P}QR + PQ\overline{R} + PQR.$ [1]

Question 4:

Write the Product of Sum form of the function F(X, Y, Z) for the following truth table representation of F :

X	Y	Z	F
0	0	0	1
0	0	1	0
0	1	0	0
0	1	1	1
1	0	0	0
1	0	1	0
1	1	0	1
1	1	1	1

[O.D, 2014]

Ans. $(X+Y+\overline{Z}).(X+\overline{Y}+Z).(X+\overline{Y}+Z).(X+\overline{Y}+\overline{Z}).$

Question 5:

Write the Product of Sum form of the function $G(U, V, W)$ for the following truth table representation of G :

U	V	W	$G(U, V, W)$
0	0	0	0
0	0	1	1
0	1	0	0
0	1	1	1
1	0	0	1
1	0	1	0
1	1	0	1
1	1	1	0

[CBSE Comptt., 2013]

Ans. $(U + V + W) \cdot (U + \bar{V} + W) \cdot (\bar{U} + V + \bar{W}) \cdot (\bar{U} + \bar{V} + \bar{W})$. [1]

Question 6:

Write the Product of Sum form of function $G(U, V, W)$ for the following truth table representation of G :

Maxterm

U	V	W	G
0	0	0	1
0	0	1	0
0	1	0	1
0	1	1	0
1	0	0	1
1	0	1	0
1	1	0	0
1	1	1	1

Ans.

U	V	W	G	POS
0	0	0	1	
0	0	1	0	$U + V + \bar{W}$
0	1	0	1	
0	1	1	0	$U + \bar{V} + \bar{W}$
1	0	0	1	
1	0	1	0	$U + V + \bar{W}$
1	1	0	0	$U + V + \bar{W}$
1	1	1	1	

$$\text{POS} = (U + V + \bar{W}).(U + \bar{V} + \bar{W}).(\bar{U} + V + \bar{W}).(\bar{U} + \bar{V} + W) \quad [1]$$

Question 7:

Write the Sum of Product form of the function F(A, B, C) for the following truth table representation of

Minterm .

A	B	C	F
0	0	0	0
0	0	1	0
0	1	0	1
0	1	1	1
1	0	0	1
1	0	1	0
1	1	0	0
1	1	1	1

Ans.

A	B	C	F	SOP
0	0	0	0	
0	0	1	0	
0	1	0	1	A'BC'
0	1	1	1	A'BC
1	0	0	1	AB'C'
1	0	1	0	
1	1	0	0	
1	1	1	1	ABC

$$\text{SOP} = A'BC' + A'BC + AB'C' + ABC$$

Question 8:

Write the SOP form of a boolean function F, which is represented in a truth table as follows:

X	Y	Z	F
0	0	0	1
0	0	1	0
0	1	0	1
0	1	1	0
1	0	0	1
1	0	1	0
1	1	0	0
1	1	1	1

Answer:

$$F(X, Y, Z) = X'.Y'.Z' + X'.Y.Z' + X.Y'.Z' + X.Y.Z$$

Question 9:

Write the POS form of boolean function G, which is represented in a truth table as follows :

A	B	C	G
0	0	0	0
0	0	1	1
0	1	0	1
0	1	1	0
1	0	0	0
1	0	1	0
1	1	0	1
1	1	1	1

Answer:

$$G(A, B, C) = (A + B + C) \cdot (A + B' + C') \cdot (A' + B + C) \cdot (A' + B + C')$$

Short Answer Type Questions-II

Question 1:

Obtain the minimal SOP form for the following Boolean expression using K-Map.

$$F(A,B,C,D) = \sum (0,2,3,5,7,8,10,11,13,15)$$

Answer:

A \ CD		CD			
		C'D'	C'D	CD	CD'
A	A'B' 00	1		1	1
	A'B 01		1	1	
	AB 11		1	1	
	AB' 10	1		1	1

Quad 1 = $m_0 + m_2 + m_8 + m_{10} = B'D'$
Quad 2 = $m_3 + m_7 + m_{15} + m_{11} = CD$
Quad 3 = $m_5 + m_7 + m_{15} + m_{13} = BD$
Minimal SOP = $B'D' + CD + BD$

Question 2:

Reduce the following Boolean expression using

K-Map :

$$F(A,B,C,D) = \sum (0,1,2,4,5,6,8,10)$$

Answer:

	C+D	C+D	C'+D'	C'+D
A+B	0	0		0
A+B'	0	0		0
A'+B'				
A+B	0			0

$$F(A, B, C, D) = \pi(0, 1, 2, 4, 5, 6, 8, 10) \quad F = (A + C).(A + D).(B + D)$$

Question 3:

Reduce the following using K-Map :

$$F(A, B, C, D) = \sum(1, 3, 4, 5, 6, 7, 12, 13)$$

Answer:

$$\bar{A}B + \bar{A}D + B\bar{C}$$

		CD			
		$\bar{C}\bar{D}$	$\bar{C}D$	CD	$C\bar{D}$
AB	$\bar{A}\bar{B}$	0	1	1	
	$\bar{A}B$	1	1		1
1 AB	$A\bar{B}$	1	1		
	AB				
		8	9	11	10

Question 4:

Reduce the following boolean expression using K-map.

$$F(E, Q, R, S) = \sum(0, 2, 4, 5, 6, 7, 8, 10, 13, 15).$$

Answer:

$$\overline{P}Q + \overline{Q}\overline{S} + QS.$$

		RS			
PQ		$\overline{R}\overline{S}$	$\overline{R}S$	RS	$R\overline{S}$
$\overline{P}\overline{Q}$	1				1
	0	1		3	2
$\overline{P}Q$	1	1	1	1	1
	4	5	7	6	
$P\overline{Q}$		1	1		
	12	13	15	14	
PQ	1				1
	8	9	11	10	

Question 5:

Reduce the following Boolean Expression using K-Map :

$$F(P, Q, R, S) = \sum(1,2, 3,4,5, 6, 7, 8,10)$$

Answer:

		$R'S'$	$R'S$	RS	RS'
$P'Q'$	0	1	1		1
	0	1	3	2	
$P'Q$	1	1	1	1	
	4	5	7	6	
PQ	0	0	0	0	0
	12	13	15	14	
PQ'	1	0	0		1
	8	9	11	10	

$$F(P, Q, R, S) = P'Q + P'S + P'R'S' + PQ'S'$$

Question 6:

Reduce the following Boolean Expression using

K-Map :

$$F(A, B, C, D) = \sum(2, 3,4,5, 6, 7,8,10,11)$$

	A'B'	A'B	AB	AB'
C'D'		1		1
C'D		1		
CD	1	1		1
CD'	1	1		1

Or *

	C'D'	C'D	CD	CD'
A'B'			1	1
A'B	1	1	1	1
AB				
AB'	1		1	1

$$F(A, B, C, D) = A'B + A'C + B'C + ABD'$$

Long Answer Type Questions [4 marks each]

Question 1:

Verify the following using Boolean Laws :

[Delhi, 2016]

$$A' + B' \cdot C = A' \cdot B' \cdot C' + A' \cdot B \cdot C' + A' \cdot B \cdot C + A' \cdot B' \cdot C + A \cdot B' \cdot C$$

Answer:

$$A' + B'C = A'B'C' + A'BC' + A'BC + A'B'C + ABC$$

$$= A'C'(B'+B) + A'C \text{ (Grouping)}$$

$$(B+B') + AB'C$$

$$\Rightarrow A'C' + A'C + AB'C$$

$$(x+x'y=x+y)$$

$$\Rightarrow A'(C+C') + AB'C$$

$$\Rightarrow A' + AB'C$$

$$(x+x'=1)$$

$$\Rightarrow A' + B'C$$

$$X=A' \quad y=B'C$$

= LHS
Hence Proved.

Question 2:

Write the Boolean Expression for the result of the Logic Circuit as shown below :

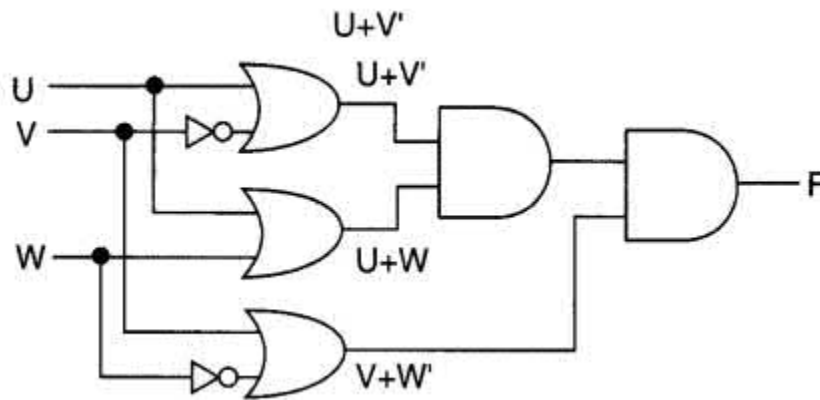

Answer:

$$F = (u+v').(u+w).(v+w')$$

Question 3:

Derive a Canonical POS expression for a Boolean function F, represented by the following truth table :

P	Q	R	F (P, Q, R)
0	0	0	0
0	0	1	1
0	1	0	1
0	1	1	0
1	0	0	0
1	0	1	0
1	1	0	1
1	1	1	1

Answer:

$$F = \sum(0, 3, 4, 5)$$

$$= (P + Q + R) (P + Q' + R') (P' + Q + R) (P' + Q + R')$$

Question 4:

Reduce the following Boolean Expression to its simplest form using K-Map :

$$F (X, Y, Z, W)$$

$$\sum(2,6,7,8,9,10,11,13,14,15)$$

Answer:

$\Sigma(2,6,7,8,9,10,11,13,14,15)$

	Z'W'	Z'W	ZW	ZW'
X'Y'	0	1	3	1 2
X'Y	4	5	7 1	1 6
XY	12	13 1	11 15	1 14
XY'	8 1	9 1	10 1	1 10

$$F = XY' + ZW' + XW + YZ$$

Question 5:

Write the Boolean Expression for the result of the Logic Circuit as shown below :

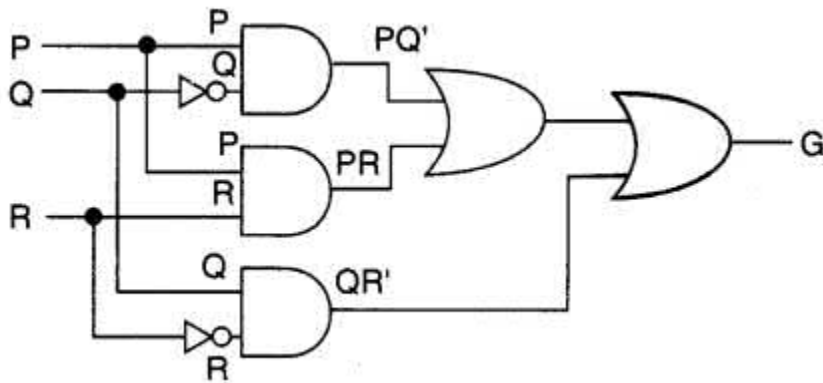

Answer:

$$G = PQ' + PR + QR'$$

Question 6:

Derive a Canonical SOP expression for a Boolean function G, represented by the following truth table :

A	B	C	G(A, B, C)
0	0	0	1
0	0	1	0
0	1	0	1
0	1	1	0
1	0	0	0
1	0	1	0
1	1	0	1
1	1	1	1

Answer:

$$G = \sum\{(0,2,6,7)\}$$

$$= A'B'C' + A'BC' + ABC' + ABC$$

Question 7:

Verify the following using Boolean Laws :

$$X' + Y'Z = X' \cdot Y' \cdot Z' + X' \cdot Y \cdot Z' + X' \cdot Y \cdot Z + X' \cdot Y' \cdot Z + X \cdot Y' \cdot Z$$

Answer:

$$X' + Y'Z = X' \cdot Y' \cdot Z' + X' \cdot YZ' + X' \cdot YZ + X' \cdot Y' \cdot Z + XY' \cdot Z$$

Taking RHS

Grouping terms

$$\Rightarrow X'Z'(Y'+Y) + X'Z(Y+Y') + XY'Z$$

$$\Rightarrow X'Z' + X'Z + XY'Z$$

$$(Y+Y'=1)$$

$$\Rightarrow X'(Z'+Z) + XY'Z$$

(Grouping)

$$\Rightarrow X' + XY'Z (Z+Z'=1)$$

$$\Rightarrow X' + Y'Z \text{ (Substitute } X=X' \text{ } Y=Y'Z \text{ } X+X' \cdot Y = X+Y)$$

$$= \text{LHS}$$

Question 8:

Reduce the following Boolean Expression to its simplest form using K-Map :

$$F(P, Q, R, S) = \sum(0, 4, 5, 8, 9, 10, 11, 12, 13, 15)$$

Answer:

$$F(P, Q, R, S) = \sum(0, 4, 5, 8, 9, 10, 11, 12, 13, 15)$$

	R'S'	R'S	RS	RS'
P'Q'	1'S 0	1	3	2
P'Q	1'S 4	1'S 5	7	6
PQ	1'S 12	1'S 13	1'S 15	14
PQ'	1'S 8	1'S 9	1'S 11	1'S 10

$$F = R' S' + PQ' + QR' + PS$$